

Nominal Size W x H x D (in)	Actual Size W x H x D (in)	Part Number	Capacity (CFM)	Resistance (in W.G.)	Media Area (sq ft)	Carton Qty	Weight per Carton (lbs)
24 x 24 x 2	23-3/8 x 23-3/8 x 1-3/4	120-612-2424	2000	0.41	38	6	23
25 x 20 x 2	24-3/8 x 19-3/8 x 1-3/4	120-612-2520	1750	0.41	33	6	20
20 x 24 x 2	19-3/8 x 23-3/8 x 1-3/4	120-612-2024	1675	0.41	32	6	20
20 x 20 x 2	19-3/8 x 19-3/8 x 1-3/4	120-612-2020	1400	0.41	26	6	16
18 x 24 x 2	17-3/8 x 23-3/8 x 1-3/4	120-612-1824	1500	0.41	28	6	18
18 x 20 x 2	17-3/8 x 19-3/8 x 1-3/4	120-612-1820	1250	0.41	23	6	15
25 x 16 x 2	24-3/8 x 15-3/8 x 1-3/4	120-612-2516	1400	0.41	26	6	16
16 x 24 x 2	15-3/8 x 23-3/8 x 1-3/4	120-612-1624	1350	0.41	25	6	16
16 x 20 x 2	15-3/8 x 19-3/8 x 1-3/4	120-612-1620	1125	0.41	21	6	13
14 x 20 x 2	13-3/8 x 19-3/8 x 1-3/4	120-612-1420	975	0.41	19	6	12
12 x 24 x 2	11-3/8 x 23-3/8 x 1-3/4	120-612-1224	1000	0.41	19	12	24

Standard Construction:

1. Synthetic Media
2. Hotmelt Adhesive Media Separators
3. HIPS Frame - Black

Specifications:

1. Efficiency: Per ASHRAE 52.2-2017 standard
2. Final Resistance: 1.5" W.G.
3. Rated Velocity: 500 FPM
4. Classified per UL Standard 900
5. Maximum Operating Temperature: 150 degrees F (66 C)
6. Tolerance: Height & Width - +/- 1/8"
7. Tolerance: Depth - +/- 1/16"

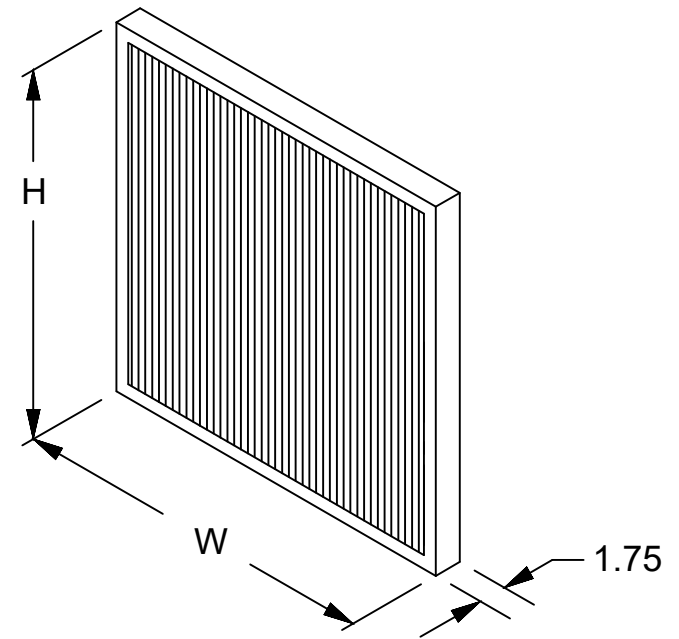

**Micromax PL2S
MERV 15**

REV
LTR

REVISION

BY /
DATE

8401 Air Commerce Drive - Louisville KY 40219
Phone: (502) 634-4796 FAX: (502) 637-2280

Drawn By: Brent Chamberlain
Date: July 22, 2024

Revision